

SETHI HEAVY ENGINEERING

Photographic Representation of Life Cycle

for Repair and Reconditioning
of

M/s Lakshmi Cement's (Sirohi)

HR Press Roller

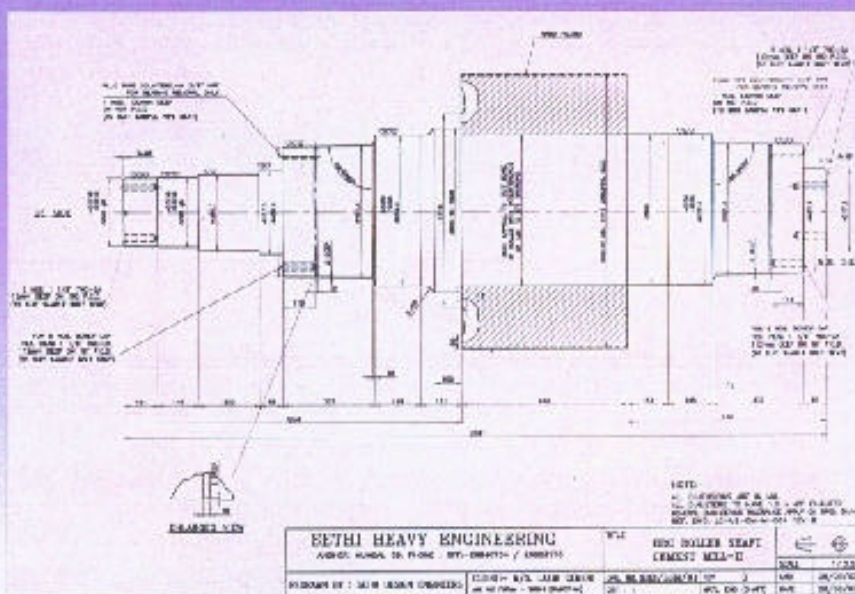

Order no. : LCWP/REP/0600/02/03 Dt. 14.08.03 & LCWP/REP/3982/2003 Dt. 10.09.03

BREAKDOWN JOB COMPLETED IN A RECORD OF 29 DAYS
WE DARE TO DREAM THE IMPOSSIBLE

SETHI HEAVY ENGINEERING

Redefining Engineering

OM: 603, FLYOVER APARTMENTS, END OF FLYOVER, TELLI GALLI, ANCHERI-EAST, MUMBAI-400 089. Tel:- 022- 26840734 / 26823173 Fax. 26820853.

PERFECTION THROUGH CONTINUOUS AND CONSTANT IMPROVEMENT

HP

Hydraulic Roller Press

- 1 Grinding rollers with adjustable wear faces
- 2 Oil immersion pumps for roller cooling
- 3 Roller sets with built-in gear
- 4 Temperature & vibration #
- 5 Safety, interlock, coaching
- 6 Wash water
- 7 Hydraulic with variable speed motor
- 8 Interoperable hydraulic actuators
- 9 Drive roller
- 10 Roll Press
- 11 Enclosures
- 12 Storage & discharge system
- 13 Lubrication & filter
- 14 Temperature control

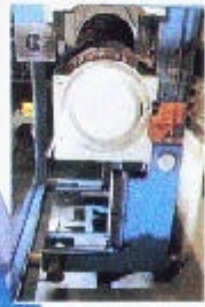
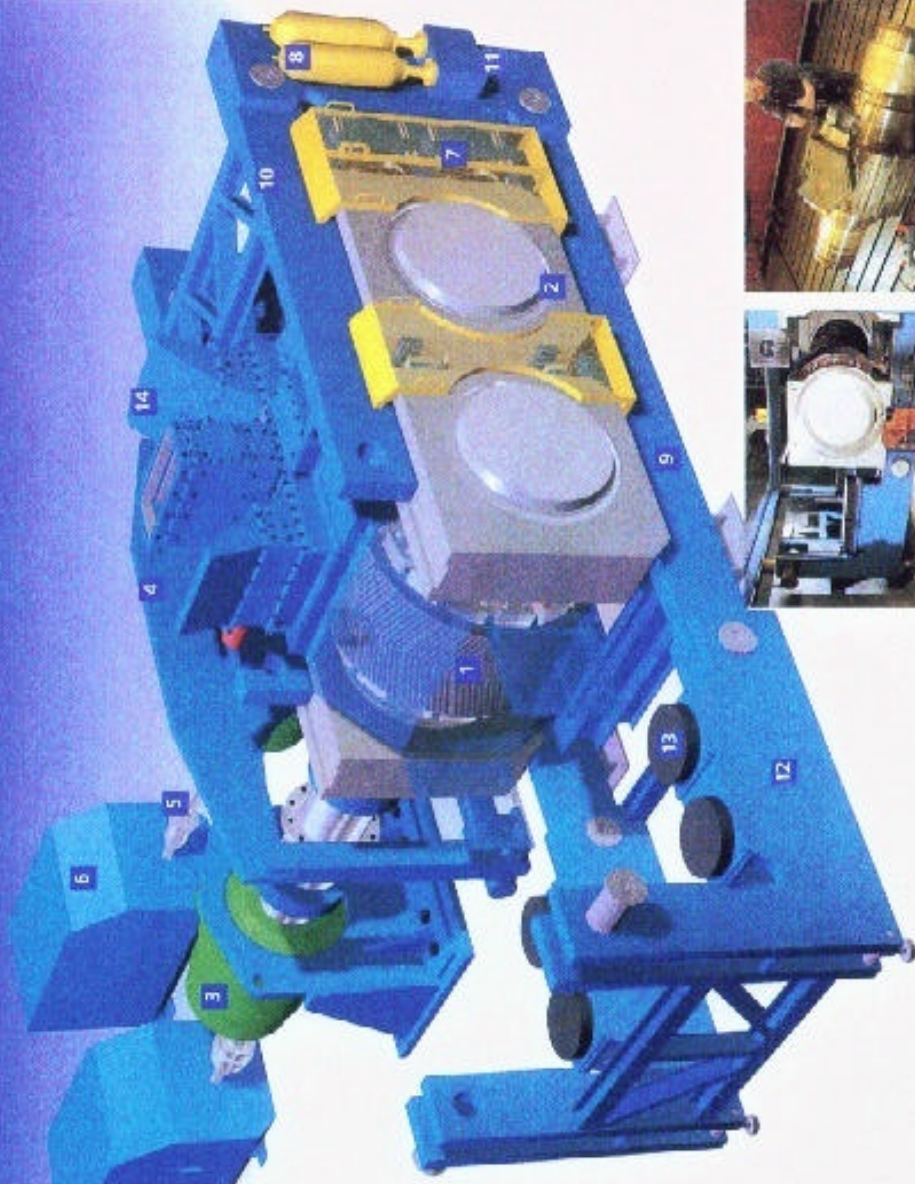

BREAKDOWN JOB COMPLETED IN A RECORD OF 29 DAYS
WE DARE TO DREAM THE IMPOSSIBLE



SETHI HEAVY ENGINEERING

Redefining Engineering

Off: 903, FLYOVER APARTMENTS, END OF FLYOVER, TELLI GALLI, ANCHERI-EAST, MUMBAI-400 069. Tel: 022-26840734 / 26823173 Fax: 26820653.

PERFECTION THROUGH CONTINUOUS AND CONSTANT IMPROVEMENT



SETHI HEAVY ENGINEERING

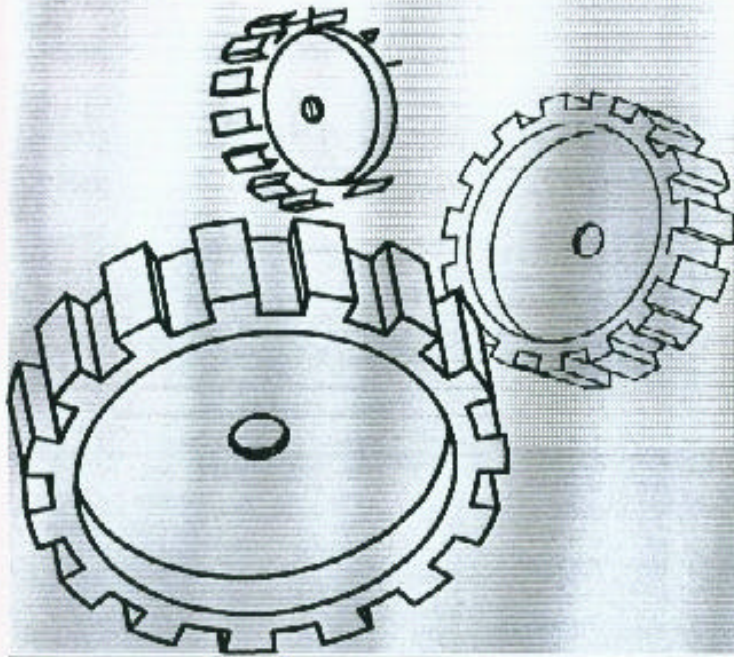

HRC ROLLER SHAFT MACHINING

SETHI HEAVY ENGINEERING

Redefining Engineering

OFF: 003, FLYOVER APARTMENTS, END OF FLYOVER, TELLI GALLI, ANDHERI-EAST, MUMBAI-400 069 Tel:- 022- 26840734 / 26823173 Fax: 26820853

PERFECTION THROUGH CONTINUOUS AND CONSTANT IMPROVEMENT

SETHI HEAVY ENGINEERING

Redefining Engineering

Off: 603, FLYOVER APARTMENTS, END OF FLYOVER, TELLI GALLI, ANDHERI-EAST, MUMBAI-400 089. Tel. - 022- 26840734 / 26823173 Fax: 26820853

PERFECTION THROUGH CONTINUOUS AND CONSTANT IMPROVEMENT



EN 8 Shaft checked
Ultrasonically & Chemically
and found O.K. being loaded
on lathe.

Dia : 610 mm x 3400 mm long



Heavy cut taken on Tool Point
to ensure
timely Proof Machining

Client : M/s. Lakshmi Cement (Sirohi) Job : HRC Roller

Order no. : LCWP/REP/0600/02/03 Dt. 14.08.03 & LCWP/REP/3982/2003 Dt. 10.09.03

SETHI HEAVY ENGINEERING

Redefining Engineering

Off: 603, FLYOVER APARTMENTS, END OF FLYOVER, TELLI GALLI, ANDHERI EAST, MUMBAI-400 069. Tel: 022 26840734 / 26823173 Fax: 26820893.

PERFECTION THROUGH CONTINUOUS AND CONSTANT IMPROVEMENT



Proof Machined Stepped Shaft
being loaded into Furnace for
Stress Relieving.

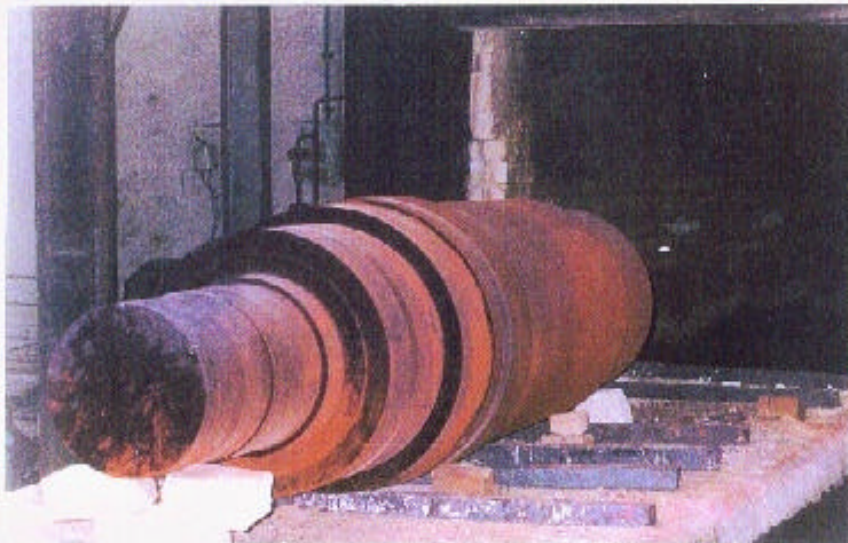

Fully stress relieved Shaft
removed after special cycle of
soaking for 16 hours at 650
degrees centigrade. Heat
Input @ 50 degrees per hour
approx.

Client : M/s. Lakshmi Cement (Sirohi) Job : HRC Roller

Order no. : LCWP/REP/0600/02/03 DL 14.08.03 & LCWP/REP/3982/2003 DL 10.09.03

SETHI HEAVY ENGINEERING

Redefining Engineering

Off. 603, FLYOVER APARTMENTS, END OF FLYOVER, TELLI GALLI, ANDHERI-EAST, MUMBAI-400 069. Tel.- 022- 26846734 / 26821473 Fax- 26820853

PERFECTION THROUGH CONTINUOUS AND CONSTANT IMPROVEMENT

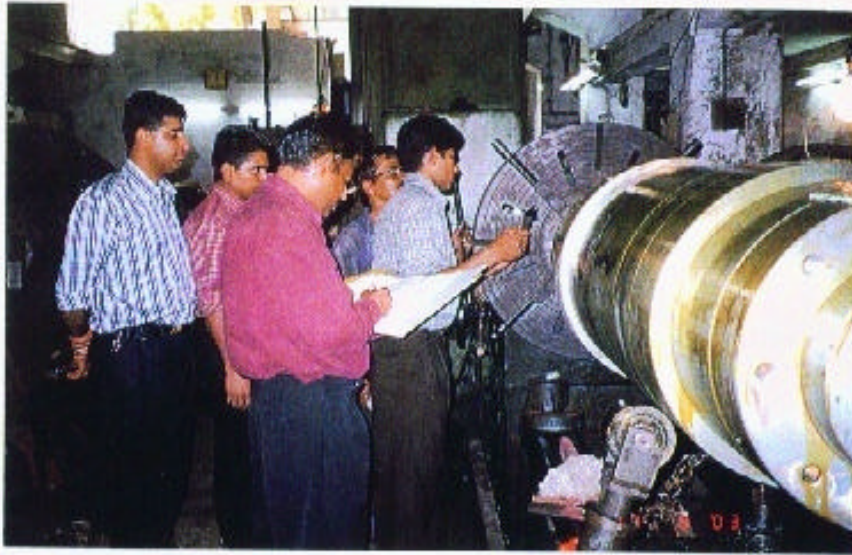

Fully machined Shaft being inspected by
Shri Kishan Singh Ji
& Shri Naidu ji of
M/s. Lakshmi Cement on lathe.



Shri Kishan Singh Ji of
M/s. Lakshmi Cement
checking fully ground shaft .
Grinding carried out on 6 mtrs.
center to center grinding m/c.

Client : M/s. Lakshmi Cement (Sirohi) Job : HRC Roller

Order no. : LCWP/REP/0600/02/03 Dt. 14.08.03 & LCWP/REP/3982/2003 Dt. 10.09.03

SETHI HEAVY ENGINEERING

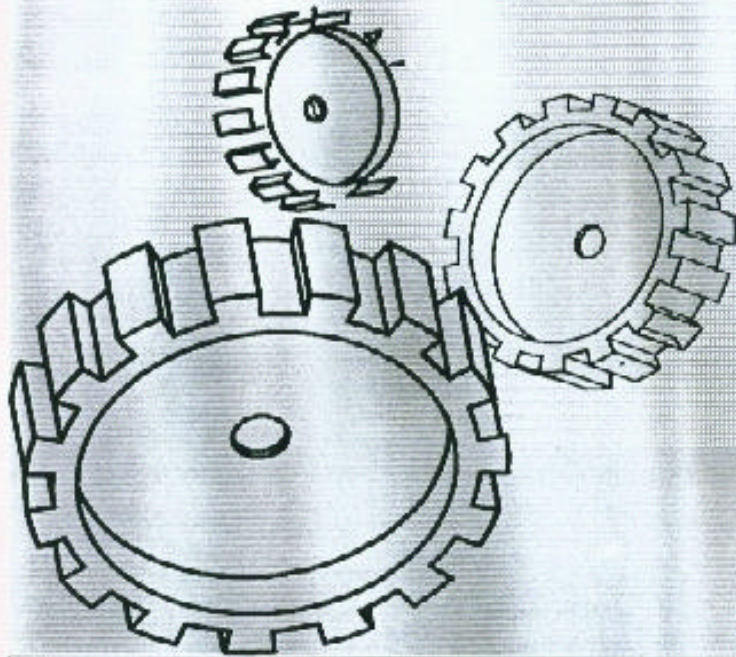

HRC ROLLER MACHINING

SETHI HEAVY ENGINEERING

Redefining Engineering

Off: 603, FLYOVER APARTMENTS, END OF FLYOVER, TELLI GALLI, ANDHERI EAST, MUMBAI-400 069. Tel: 022- 26840734 / 26823173 Fax: 26820663.

PERFECTION THROUGH CONTINUOUS AND CONSTANT IMPROVEMENT

SETHI HEAVY ENGINEERING

Redefining Engineering

Off: 803, FLYOVER APARTMENTS, END OF FLYOVER, TELLI GALLI, ANDHERI-EAST, MUMBAI-400 069. Tel:- 022- 26840734/26823173 Fax: 26820853.

PERFECTION THROUGH CONTINUOUS AND CONSTANT IMPROVEMENT

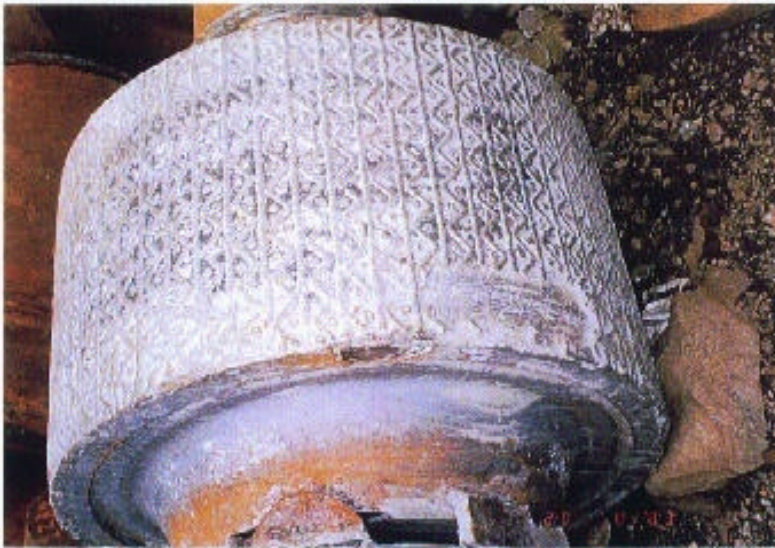

Broken HRC Roller received
and unloaded – taken up for
machining immediately

HRC Roller being fully bored
on Vertical Turret Lathe (VTL)

Material removal :
Aprox. 1.2 tonnes plus

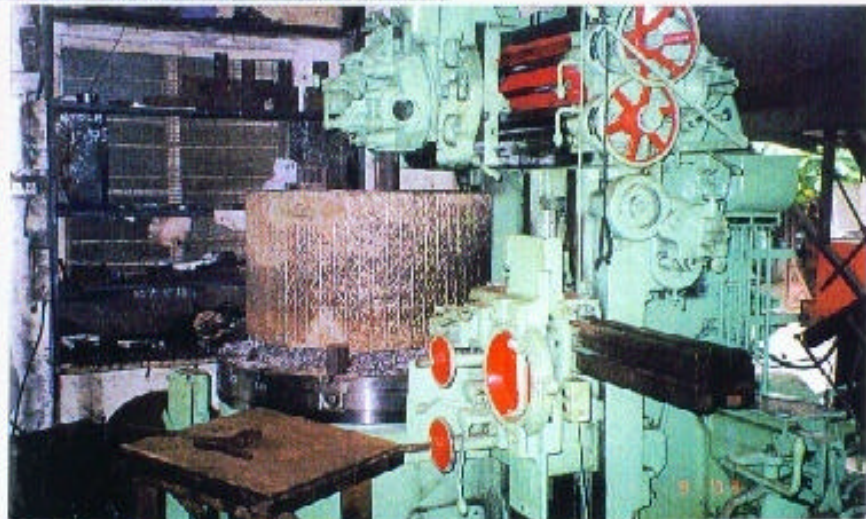

Shri Kishan Singh ji &
Shri Naidu ji of
M/s. Lakshmi Cement
checking final diameter of bore
of finish bored roller.

Client : M/s. Lakshmi Cement (Sirohi) Job : HRC Roller

Order no. : LCWP/REP/0600/02/03 Dt. 14.08.03 & LCWP/REP/3982/2003 Dt. 10.09.03

SETHI HEAVY ENGINEERING

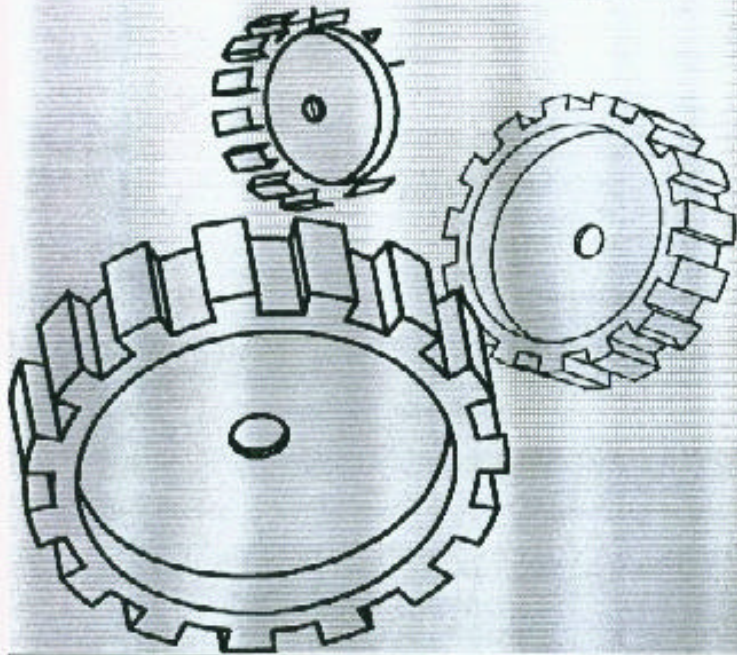

TESTING LAB FACILITIES & HEAT TREATMENT

SETHI HEAVY ENGINEERING

Redefining Engineering

Off: 603, FLYOVER APARTMENTS, END OF FLYOVER, TELI GALLI, ANDHERI-EAST, MUMBAI-400 069. Tel - 022- 26840734 / 26823173 Fax. 26820853.

PERFECTION THROUGH CONTINUOUS AND CONSTANT IMPROVEMENT

SETHI HEAVY ENGINEERING

Redefining Engineering

Off: 603, FLYOVER APARTMENTS, END OF FLYOVER, TELLI GALLI, ANDHERI-EAST, MUMBAI-400 069. Tel:- 022- 26840734 / 26823173 Fax. 26820853.

PERFECTION THROUGH CONTINUOUS AND CONSTANT IMPROVEMENT



Shri Kishan Singh ji being explained various procedures of testing at M/s. Metallurgical Services. (ISO 9002 and NABL approved)



Shri Kishan Singh ji & Shri Naidu ji being explained Physical & Chemical testing systems.

Client : M/s. Lakshmi Cement (Sirohi) Job : HRC Roller

Order no. : LCWP/REP/0600/02/03 Dt. 14.08.03 & LCWP/REP/3982/2003 Dt. 10.09.03

SETHI HEAVY ENGINEERING

Redefining Engineering

Off: 603, FLYOVER APARTMENTS, END OF FLYOVER, TEL LI GALLI, ANDHERI-EAST, MUMBAI-400 069. Tel. - 022- 26840734 / 26823173 Fax. 26820853.

PERFECTION THROUGH CONTINUOUS AND CONSTANT IMPROVEMENT



Visit to
Spectrography Section
of Lab



Visit to Physical
& Mechanical testing
section of Lab.

Client : M/s. Lakshmi Cement (Sirohi) Job : HRC Roller

Order no. : LCWP/REP/0600/02/03 Dt. 14.08.03 & LCWP/REP/3982/2003 Dt. 10.09.03

SETHI HEAVY ENGINEERING

Redefining Engineering

Off: 603, FLYOVER APARTMENTS, END OF FLYOVER, TELLI GALLI, ANDHERI EAST, MUMBAI 400 068. Tel: 022-26840734 / 26823173 Fax: 26820853.

PERFECTION THROUGH CONTINUOUS AND CONSTANT IMPROVEMENT



Various aspects of Heat treatment viz. Stress relieving of Shaft being explained to Shri Kishan Singh ji & Shri Naidu ji



Client : M/s. Lakshmi Cement (Sirohi) Job : HRC Roller

Order no. : LCWP/REP/0600/02/03 Dt. 14.08.03 & LCWP/REP/3982/2003 Dt. 10.09.03

SETHI HEAVY ENGINEERING

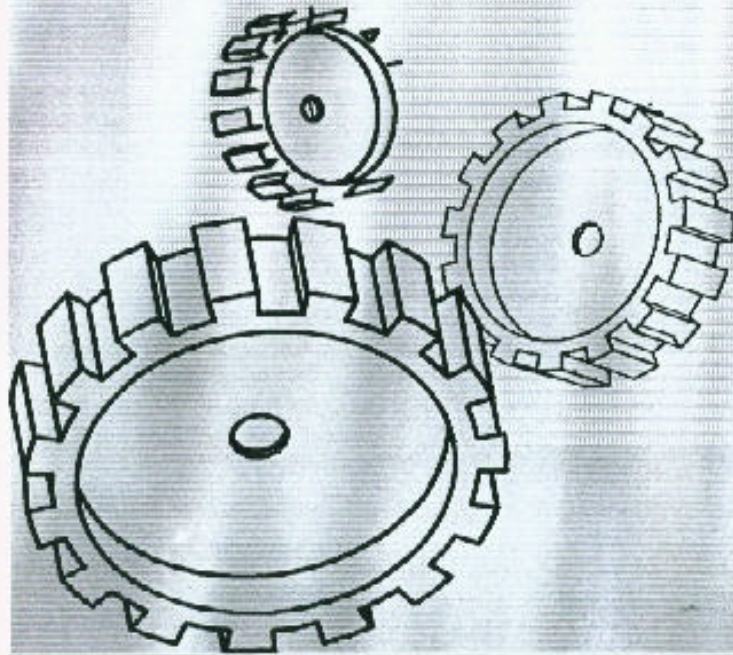

SHRINK FITTING, WELDING & DESPATCH

SETHI HEAVY ENGINEERING

Redefining Engineering

Off: 603, FLYOVER APARTMENTS, END OF FLYOVER, TELLI GALLI, ANDHERI-EAST, MUMBAI-400 089. Tel: 022- 26840734 / 26823173 Fax: 26820853.

PERFECTION THROUGH CONTINUOUS AND CONSTANT IMPROVEMENT

SETHI HEAVY ENGINEERING

Redefining Engineering

OFF: 603, FLYOVER APARTMENTS, END OF FLYOVER, TILIGALLI, ANDHERI-EAST, MUMBAI-400 069. Tel:- 022- 26840734 / 26823173 Fax: 26820853.

PERFECTION THROUGH CONTINUOUS AND CONSTANT IMPROVEMENT

Cooling of Shaft
using Dry Ice
Prior to
Shrink Fitting



Lifting & Cleaning of Shaft
Just before Shrink Fitting.
(Please note Bearing Inner
Race on taper portion already
fitted on Shaft)

Shaft being lifted
For insertion
into heated Roller



Client : M/s. Lakshmi Cement (Sirohi) Job : HRC Roller

Order no. : LCWP/REP/0600/02/03 Dt. 14.08.03 & LCWP/REP/3982/2003 Dt. 10.09.03

SETHI HEAVY ENGINEERING

Redefining Engineering

Off. 603, FLYOVER APARTMENTS, END OF FLYOVER, TELLI GALLI, ANDHERI-EAST, MUMBAI-400 069. Tel.- 022- 26840734 / 26823173 Fax: 26820853

PERFECTION THROUGH CONTINUOUS AND CONSTANT IMPROVEMENT



Inner Heating Coil being removed from bore of Roller.
Outer Coil still intact.

Shaft being lowered carefully into heated bore of Roller

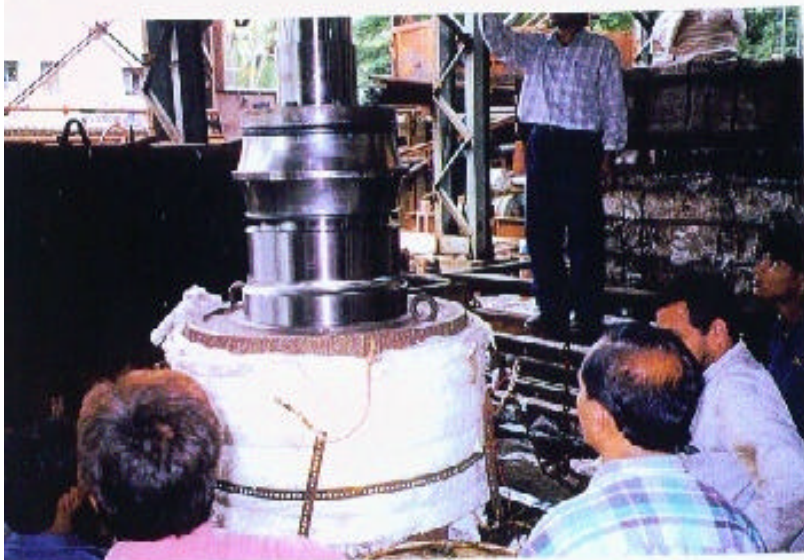

Collar of Shrink Fitted Shaft perfectly seated in bore of Roller at required depth.
Shrink Fitting completed.

Client : M/s. Lakshmi Cement (Sirohi) Job : HRC Roller

Order no. : LCWP/REP/0600/02/03 Dt. 14.08.03 & LCWP/REP/3982/2003 Dt. 10.09.03

SETHI HEAVY ENGINEERING

Redefining Engineering

OFF- 603, FLYOVER APARTMENTS, END OF FLYOVER, TELI GALLI, ANDHRI-FAST, MUMBAI-400 069 Tel:- 022- 26940734 / 26023173 Fax: 26820853.

PERFECTION THROUGH CONTINUOUS AND CONSTANT IMPROVEMENT



**Shri D. Rakshit – Sr. Manager
(L & T) EWAC Alloys along
with colleague Mr. Rao
checking preheating and
welding of Collar of Shaft.**



**Mr. Rao (L & T – EWAC),
Mr. Kishan Singh ji - (Lakshmi Cement)
Mr. P.C. Sethi (Sethi Heavy Engg.)
Mr. D. Rakshit (L & T - EWAC)**

Client : M/s. Lakshmi Cement (Sirohi) Job : HRC Roller

Order no. : LCWP/REP/0600/02/03 Dt. 14.08.03 & LCWP/REP/3982/2003 Dt. 10.09.03

SETHI HEAVY ENGINEERING

Redefining Engineering

OH: 603, FLYOVER APARTMENTS, END OF FLYOVER, TELLI GALLI, ANDHERI-EAST, MUMBAI-400 069. Tel:- 022- 26840734 / 26823173 Fax: 26820853.

PERFECTION THROUGH CONTINUOUS AND CONSTANT IMPROVEMENT



Special Golden Anti Rust being applied on Shaft ground areas (full Shaft) prior to packing.

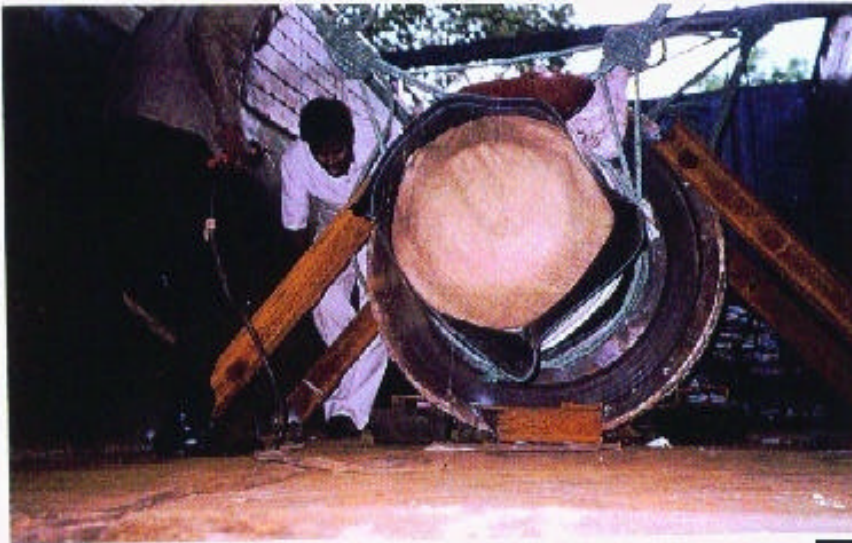

Fully packed HRC Roller loaded into Truck with stays (channel) welded to ensure safe Journey – being Inspected by Shri Kishan Singh ji.

Client : M/s. Lakshmi Cement (Sirohi) Job : HRC Roller

Order no. : LCWP/REP/0600/02/03 Dt. 14.08.03 & LCWP/REP/3982/2003 Dt. 10.09.03

Job : HRP Roller (Lakshmi Cement - Sirohi)

List of Inspection Reports

handed over personally to Shri Kishan Singh ji in special file :

- Spectro Chemical Analysis Report for Shaft (T/5486 Dt. 13.08.03)
- Certificate of Approval (IS 9002) for Lab
- Certificate of Approval (NABL) for Lab for Accreditation
 - For Chemical Testing
 - For Mechanical Testing
- Ultrasonic Test Certificate for Roller from IXAR (Dated 17.09.03)
- Ultrasonic Test Certificate for Shaft from IXAR (Dated 17.09.03)
- Stress Relieving Graph for Shaft - 16 Hrs Soaking at 650 degree
(Dated 01.09.03)
- Inspection Report for dimensional check for Roller (Dated 12.09.03)
- Inspection Report for dimensional check for Shaft (Dated 15.09.03)
- Inspection Report for dimensional check for Shaft - Post Grinding
(Dated 20.09.03)
- Shrink fitting graph (Dated 22.09.2003)

Order no. : LCWP/REP/0600/02/03 Dt. 14.08.03 & LCWP/REP/3982/2003 Dt. 10.09.03

SETHI HEAVY ENGINEERING

Redefining Engineering

Off: 603, FLYOVER APARTMENTS, END OF FLYOVER, TELLI GALLI, ANDHERI-EAST, MUMBAI-400 069. Tel.: 022- 26840734 / 26823173 Fax: 26820853

PERFECTION THROUGH CONTINUOUS AND CONSTANT IMPROVEMENT

SETHI HEAVY ENGINEERING

WHENEVER YOU NEED A SPARE WE CERTAINLY WILL BE THERE

**Suppliers of Fabricated and Machined Spares / Import
Substitutes for the Engineering Industry
CEMENT / STEEL / SUGAR / PAPER / CHEMICAL / FERTILIZER / DEFENCE**

Facilities at our disposal are under

Heavy Fabrication Rolling and X-Ray Quality Welding (Lifting over 450 Tons)

PLATE MATERIAL: IS 2062 / IS 2002 GR B / BQ ASTM A 515 / 516 GR 60/70
STAINLESS STEEL SS 304 / 316 / 316L
HARDOX 400 / 450 / 500 / 600 & SAILHARD / TISCRA
PLATE BENDING : UPTO 120MM THICKNESS COLD & UPTO 200 MM HOT
PLATE CUTTING : UPTO 200 MM CNC GAS CUTTING / PLASMA CUTTING
WELDING: CO2 / ARGON / MMAC / SAW- BOOM TYPE / TIG / MIG
STRESS RELIEVING FURNACE : 8M X 8M X 18M

FORGED & MACHINED SHAFTS

FORGED SHAFTS: MATERIALS EN 8 / EN 9 / EN 19 / EN 24 / EN 31
/ EN 40B / EN 353 ETC / C45 / 20 MN CR 5 / 42 CR M04 V
STAINLESS STEEL SHAFTING: SS 304 / SS 310 / SS 316/L / SS 431
DIAMETERS: ROLLED : 60MM TO 180 MM X LENGTHS UPTO 5METRES
FORGED : 180 MM TO 1100 MM X LENGTHS UPTO 6METRES.
TURNING: 2000MM X UPTO 10 000 MM (LATHES)
HORIZONTAL BORING: 210MM SKODA / 160 MM TOS
VTL : FROM 1000MM TO 7000 MM

CENTRE TO CENTRE GRINDING ON 6 METRES MACHINE Diameters: 1000 mm x 6000 mm lengths

GEARS/ PINIONS: Forged /Cast & Fabricated Internal & External

SPUR / HELICAL / HERRINGBONE / BEVEL / SPIRAL BEVEL
HOBBED GEARS UPTO : 40 MODULE
FLAME HARDENED & THROUGH HARDENED

OUR STRENGTH

- ✓ A VISION TO DELIVER VALUE
- ✓ ENGINEERING EXCELLENCE WITH GLOBAL COMPETITIVENESS
- ✓ A PASSION TO EXCELL

WE STAND COMMITTED TO : Quality Workmanship Reliability & Timely Deliveries

SETHI HEAVY ENGINEERING

REDEFINING ENGINEERING

603, FLYOVER APARTMENTS, END OF FLYOVER, TELLI GALLI, ANDHERI-EAST, MUMBAI-400 969. Tel: 022-26840734 / 26823173, Fax: 022-26820853

Also Marketing Agents for: Godrej & Boyce Mfg Co. Ltd. (Precision Equipment Division / Heavy Engineering)

SETHI HEAVY ENGINEERING

Specialists in Cement Plant Spares

WHENEVER YOU NEED A SPARE, WE CERTAINLY WILL BE THERE

Repairs & Reconditioning Breakdown Jobs We dare to do the Impossible

W H E R E Q U A L I T Y I S A W A Y O F L I F E

SETHI HEAVY ENGINEERING

REDEFINING ENGINEERING

603, FLYOVER APARTMENTS, END OF FLYOVER, TELLI GALLI, ANDHERI-EAST, MUMBAI-400 069. Tel:- 022- 26840734 / 26823173, Fax:- 022- 26820653